

Stevenson Projects'

Vacationer

Paper Model By: Kevin Green

Building the Hull

1. Print out all piece sheets.
2. Cut out one keel piece and glue it to a piece of balsa wood or dense cardboard. Cut out the second keel piece and glue it to the other side of the balsa wood. (This is your keel)
3. Or glue the keel to a blank piece of paper. Cut the blank paper out around the keel piece to create a two layer keel. Repeat this 4 or 5 more times to get a rigid, sturdy keel.
4. Cut out the Main Bulkhead and the forward bulkhead.
5. Glue these to a piece of balsa or use step 3 to get solid bulkheads.

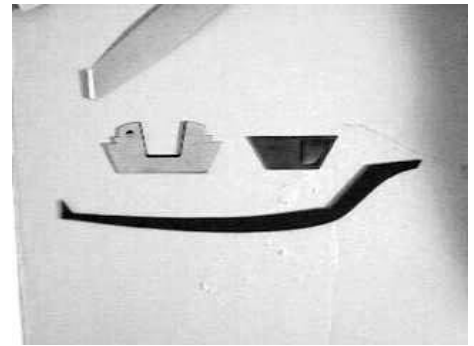
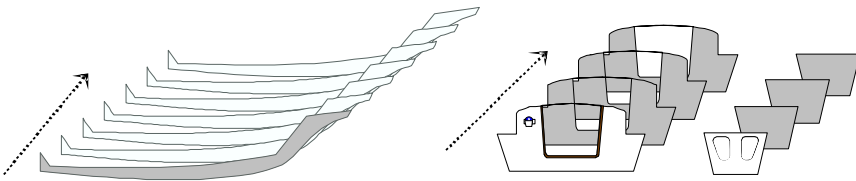

6. Cut out the Hull, Top Deck, Boat Bottom and Inside Transom.
7. Glue the Boat Bottom (printed side up) to the inside of the Hull Bottom (Non-printed side) *This will reinforce the Hull and show where the bulkheads go.
8. Glue the Separate Hull sides to the inside of the main Hull Sides. (carefull to keep glue below marked line)
9. Glue the Separate Transom to the inside of the Main Transom. (carefull to keep glue below marked line)
10. Glue the Top Deck Over the Top Deck Bottom.
11. ***The placement of these pieces being glued onto themselves is very important. You might want to fold the glue tabs up to help align the pieces.

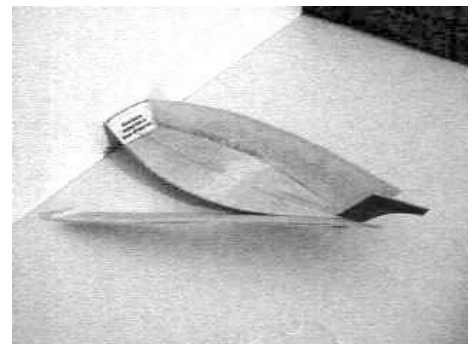
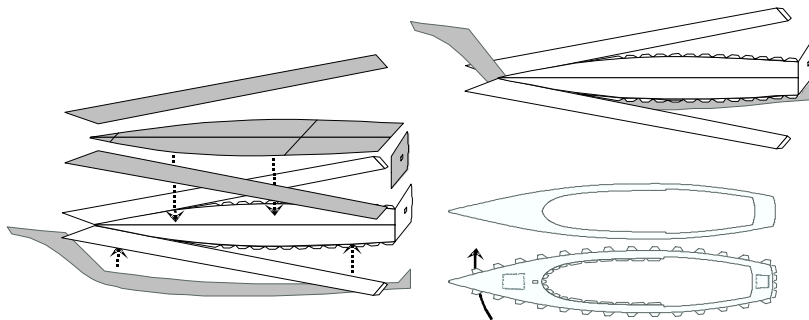

12. Glue the Hull bottom to the Keel.
13. Fold up the Hull sides, Transom and Glue Tabs.
14. Working from front to back, glue the Hull Sides to the Hull Bottom.
15. Glue the rear Glue Tabs on the Hull Sides to the inside of the Transom.
16. Make sure you do not glue the front of hull sides to the Stem yet.

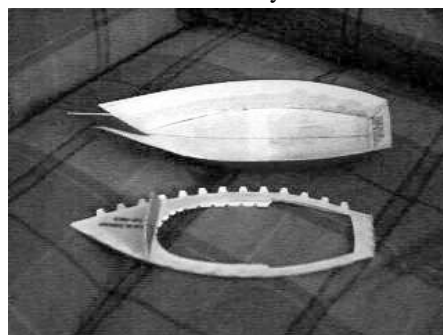

Top Deck and Bulkheads

17. Glue the Forward Bulkhead to the bottom side of the Top Deck along line. Be sure it does not cover the hole for the mast.
18. Fold all Glue Tabs on the Top Deck down.
19. Tuck the rear glue tabs in between the inside and outside Transom and glue.
20. Working from back to front and alternating sides, glue the Top Deck Glue Tabs between the inside and outside hull sides.
21. Do not glue the Forward Bulkhead down to the Hull yet.

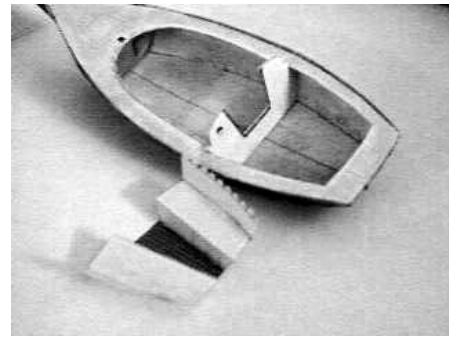
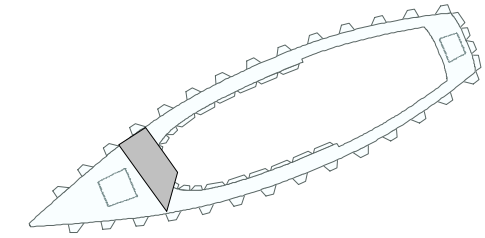
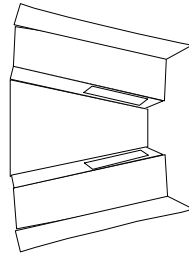
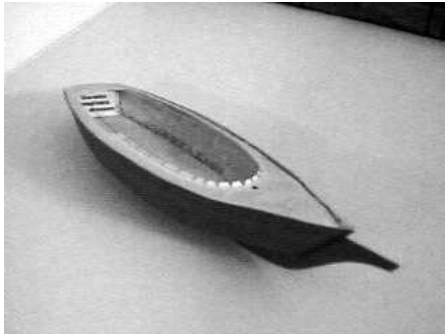

22. Position the Main Bulkhead in place. The bottom of the Main Bulkhead lines up with the line on the Boat Bottom. The Deck Supports line up with the rear end of last inside Glue Tabs.

23. Cut out the Seat Assembly.

24. Fold on the lines to form the cockpit seats and Glue the tabs of the Seat Back to the Bottom side of the seat Bottom.

25. Place the Seat Assembly inside the Cockpit of the boat.

26. Ensure that it is centered in the cockpit. Glue into place once positioned.

27. Cut out the Lazarette. Slide down behind the cockpit seats until flush with top deck, and glue.

28. Cut out the Cabin Sides Piece.

29. Glue the center of the Cabin Sides to the forward center tab of the Top Deck.

30. Working from front to back glue the Cabin Sides to the Top Deck.

31. Cut out the Cabin Roof.

32. Glue the forward center of the roof to the forward center tab on the Cabin Sides.

33. Working from front to back, glue the roof to the cabin sides all the way back to and including the Main Bulkhead. (Once the roof is on you will need to trim it to the desired amount of overhang you would like.)

34. Cut out the Cabin Hatch and Grab Rails.

35. Glue the Grab Rails to the Cabin Roof where indicated by the dotted lines.

36. Glue the Cabin Hatch to the Cabin Roof at the desired amount of opening.

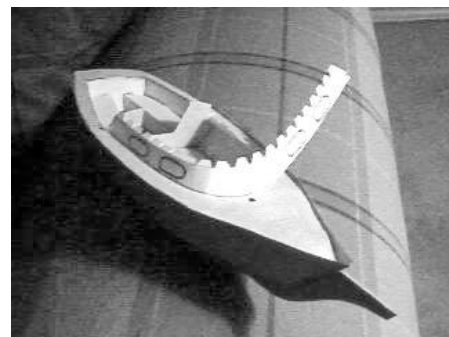
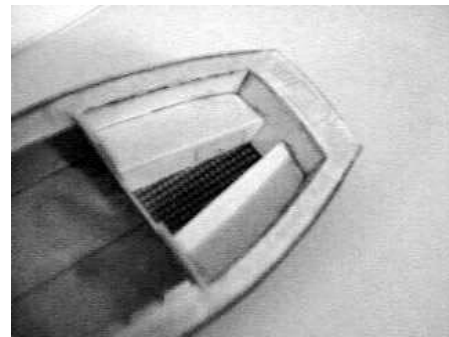

37. Cut out Cockpit Coaming.
38. Glue side coaming along the edge of the cockpit. Glue the back coaming centered on the lazarette and level with the side coaming.
39. Cut out the Taff Rail, deck hatches and portholes.
40. Glue into place.
41. Cut out the two wheel pieces, glue back to back and glue into place.

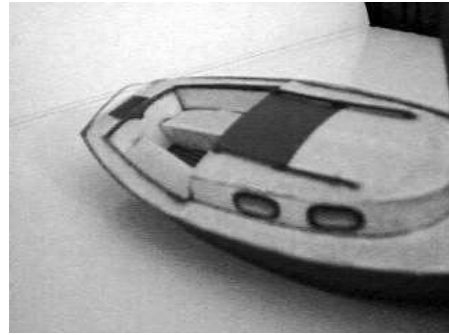

Sails and Rigging

42. Cut out the Mast, Boom, Gaff, Bowsprit and Club Foot.
43. Roll these pieces up and glue together at the Glue Tab.
44. Insert the Mast into the Mast Hole on the front deck. Ensure that it is parallel to the front of the Cabin.
45. Glue the Bowsprit to the front deck so that it is against the mast.
46. Cut out the Main Sail.

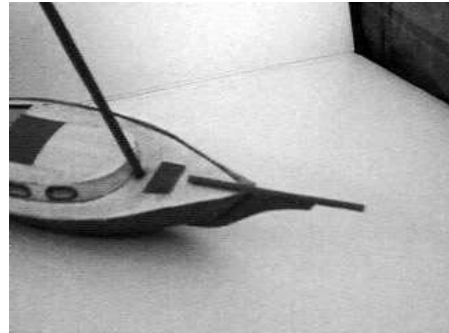

47. Split the Glue Tabs down the middle along the lines. Separate the tabs so that they fold to either side of the sail.
48. Wrap the bottom tabs around the boom and glue. Do not let the front of the boom go beyond the forward edge of the sail. This allows room for the Mast.
49. Wrap the top tabs around the Gaff and glue. Again leaving room for the Mast.
50. Wrap the forward tabs around the Mast and Glue.

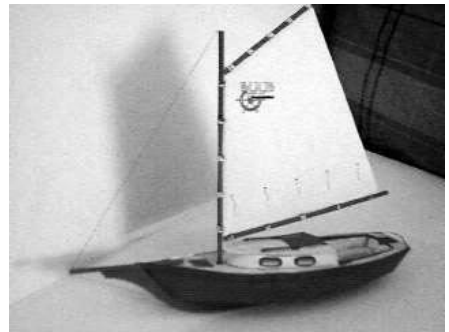
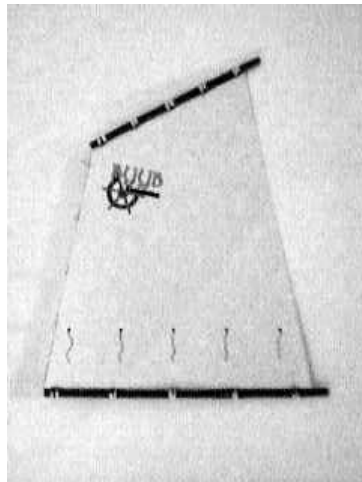

51. Glue a piece of string from the top of the mast to the tip of the Bowsprit, then to the center of the Stem. This is your Forestay.
52. Cut out the Dead Eyes. (You don't have to use these, I just like the looks of them and they make it easier to hide the ends of the strings.)
53. Fold the Dead Eyes in half along line. Glue one side of the deadeye to the side of the Hull where the vertical shroud mark is. Repeat on opposite side of the boat.
54. Cut a piece of string long enough to go from the top of the Mast to the Deadeyes and back again.
55. Glue the center of the string to the top of the Mast running from side to side.
56. Glue one end of the string to the Deadeye on that side of the boat and glue. Fold the Dead eye up the rest of the way and glue.
57. Repeat on the opposite side.

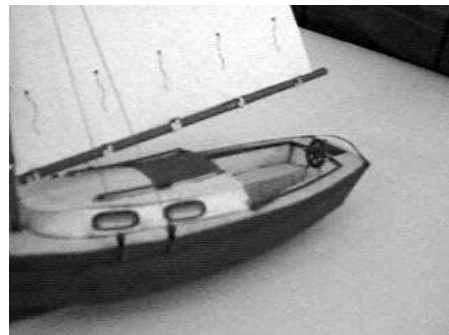
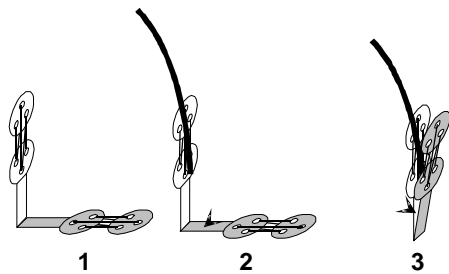

58. Cut out the Jib Sail.
59. Fold Tab back along line and glue to the Forestay between the top of the Mast and the tip of the Bowsprit.
60. Glue the clubfoot to the Free Corner of the Jib Sail then to the Bowsprit.
61. Cut out the Rudder Box and Rudder.
62. Fold the Rudder in half and insert the Rudder into the Rudder Box.
63. Glue the Rudder Box together with the Rudder inside.
64. Glue this assembly to the back of the keel.



Finishing Touches

65. If you wish you can glue the Colored Portholes to the side of the Cockpit or you can cut out the white area of the printed Portholes.
66. Cut out the BYYB Burgee, fold it in half along line and glue to one of the shrouds.
67. Cut out the pieces for the Model Stand and assemble as shown.
68. Cut out the Clip Art Man if desired. He is just to give you an idea the proportions of the boat.
69. For added effect, you can cut out the Rub Rails and glue them to the side of the boat.

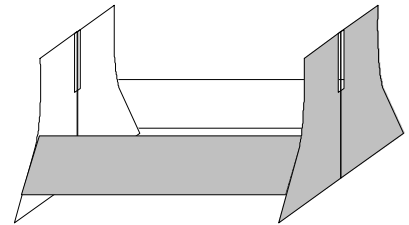
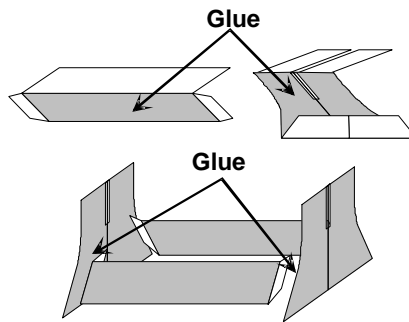

Place the boat on the stand and enjoy.

